

FARWEST

PORTLAND 2019

RULES AND REGULATIONS

FARWEST SHOW STATEMENT OF INTENT

The Farwest Show strives to provide each exhibitor with a qualified buying audience and a positive exhibition experience. A full-time professional Farwest Show staff executes a strategic marketing and production plan designed to reach horticultural buyers of plants, products and services throughout the world.

2019 FARWEST SHOW INFORMATION:

Dates: August 21 - 23 (Wednesday through Friday)

Hours: Wednesday Noon – 5pm
Thursday 10am – 5pm
Friday 10am - 2pm

Produced By:

Oregon Association of Nurseries (OAN)

29751 SW Town Center Loop W
Wilsonville, Oregon 97070

Phone: 503-682-5089 **Fax:** 503-682-5099

Email: farwest@oan.org

Web: www.farwestshow.com

CONVENTION SERVICES CONTRACTOR:

DWA is the official Farwest Trade Show decorator and drayage company:

DWA TRADE SHOW & EXPOSITION SERVICES is the contact for:

- Advanced shipment and handling
- Advance booth set-up
- Forklift and drayage service
- Furniture, carpet and display system rental
- Onsite labor services
- Traffic Manager Services

6700 NE 59th Pl
Portland, Oregon 97218
Ph: 503.228.6800 | Fax: 503.595.1470
Email: csr@dwatradeshow.com
Web: www.dwatradeshow.com

The Oregon Convention Center is the location and exclusive source for utilities, hospitality and cleaning:

OCC FACILITY EXHIBITOR SERVICES is the contact for:

- Electrical hook-up
- Water and drain
- Telephone/ internet
- Audio/visual
- Food and beverage
- Booth Cleaning

777 NE MLK Jr Blvd
Portland, OR 97232
Ph: 503-235-7575 | Fax: 503-732-7802
Email: servicedesk@oregoncc.org
Web: www.oregoncc.org

BOOTH DISPLAY RENTAL INCLUDES:

- 10' x 10' exhibit space-Main Floor
- One 8-foot-high draped back-wall, two 3-foot-high draped side rails (not included with island booth)
- One 7" x 44" Booth identification sign to include company name, city, state and booth number
- Fork lift service provided during move-in/out for privately owned vehicles
- Water/Ice for plant material
- Four exhibitor badges per 10x10 space, with a limit of 12 per company
- Complimentary code for FREE show-only attendee passes
- Exhibitor listing on www.farwestshow.com and in *Digger Magazine: Farwest Trade Show Edition*

SALE LIMITATIONS:

The Farwest Show is a closed industry trade show. Direct, individualized sale of items that are taken from any exhibit booth prior to the close of the show is prohibited. This rule is necessary in order to provide all exhibitors balanced security and to help ensure against theft. Items may be sold directly from the booth but may not be removed from the booth and/or exhibit hall until 2:00 p.m. on closing day.

SPACE ASSIGNMENT:

Any exhibiting firm occupying booth space in the Farwest Show is given first choice on that location for the subsequent year's show. Exhibitors desiring to relocate or change the size of their booth must contact the Farwest Show office. Preference will be given by exhibitor seniority status and in order of receipt.

SUB-LEASING:

Exhibit space is owned solely by the OAN, producer of the Farwest Show, and ownership is non-transferable. No exhibitor may assign, sublet or apportion the whole or any part of the booth space assigned, nor permit any other party to exhibit therein, nor distribute any promotional or advertising materials in the assigned space other than those manufactured, grown or sold by exhibitor in the normal course of his/her business. Penalty for violation may be loss of exhibit space.

PAYMENTS AND BOOTH CANCELLATIONS:

The schedule of payments due for the 2020 booth space is as follows:

September 30, 2019: First-right-of-refusal deadline for 2020 exhibit spaces and 50% deposit due.

April 30, 2020: Booth paid in full deadline (exhibitors failing to make full payment may be considered vacant and subject to re-sale).

Exhibitors who have a signed contract and paid for a booth space under the OAN member benefit rate, but have not renewed their membership for the current year will be invoiced after April 1, 2020 for the non-member booth rate. Payment will be due April 30, 2020.

New exhibitors entering the show after May 1 may make tentative reservations on available space for a period of fourteen (14) days, upon which time payment in full is due for final booth space confirmation.

2020 Contracts cancelled or modified prior to October 31, 2019, will be assessed a penalty equal to 10% of the exhibit space fee; contracts cancelled after October 31, 2019, but prior to March 31, 2020, will be assessed a penalty equal to 25% of the exhibit space fee; contracts cancelled or modified after March 31, 2020, but prior to May 31, 2020, will be assessed a penalty equal to 50% of the exhibit space fee. No refunds will be given for the 2020 exhibit space contracts cancelled or modified after May 31, 2020. All cancellations must be in writing. Exhibitor space is owned by the Oregon Association of Nurseries, Inc. and space is non-transferable from one exhibitor to another.

EXHIBITOR SOLICITING:

Exhibitors must limit their activities within the confines of the assigned booth space (which includes all marketing material) and conduct themselves in an appropriate manner that does not interfere with legitimate activities of other exhibitors. This means at no time should product or promotional materials protrude, for any distance, into the exhibit hall aisles, or be handed out in the aisle to attendees or other exhibitors without approval of show management.

NON-EXHIBITOR SOLICITING:

Show management makes every effort to protect against unauthorized selling within the show exhibit area by individuals not booking space. If exhibitors experience this with an attendee, please report them to show management. These individuals are taking advantage of exhibitors who pay for their space and abide by show rules.

CHARACTER OF EXHIBITS:

The Farwest Show retains the right to restrict exhibits to products and services of interest to and related to the nursery, horticultural and retail garden center trade. The management also reserves the right to restrict exhibits which, because of noise, method of operation, materials, or for any reason are deemed to be objectionable, and also to prohibit or evict any exhibit which, in the opinion of the management, may detract from the general character of the Farwest Show. This reservation includes persons, things, conduct, printed matter or anything of a character which the management determines objectionable. In the event of such restriction or eviction, the Farwest Show is not liable for any refunds for rentals or other exhibit expense. All exhibits must include a person(s) in their booths at all times, with the exception of minimal breaks.

DISPLAY & SIGNAGE RESTRICTIONS:

The Farwest Show works hard to maintain a professional show, which involves respecting the space and line of sight for every exhibitor. This means that if an exhibit is breaking show rules, it will be required to be changed on-site. This could be costly or timely (depending on when Show Management is made aware of this issue). Please be aware of the rules prior to designing your exhibit space.

From the aisle, the first 2 feet of your booth space is limited to 4-feet in height for solid display material. The only exception is if you are displaying items or plant material of a see-through nature. This allows attendees to get a clear view of booths from the main boulevards. You don't want your neighbor blocking your view of attendees and vice versa.

After those initial 2 feet from the aisle, there are no height restrictions. If you are using a two-sided sign(s), the side facing away from the aisle and to the back side of your booth cannot have your company name or products or logos. Signs facing toward your front aisle can include your name and logo.

The backdrop pipe and drape to your booth is not weight bearing. You can hang a very light weight banner or sign, but nothing with any real weight to it.

All displays and signage must comply with the Fire Marshall Rules and Regulations as well as Oregon Convention Center policy.

DIAGRAM 1 - SINGLE UNIT

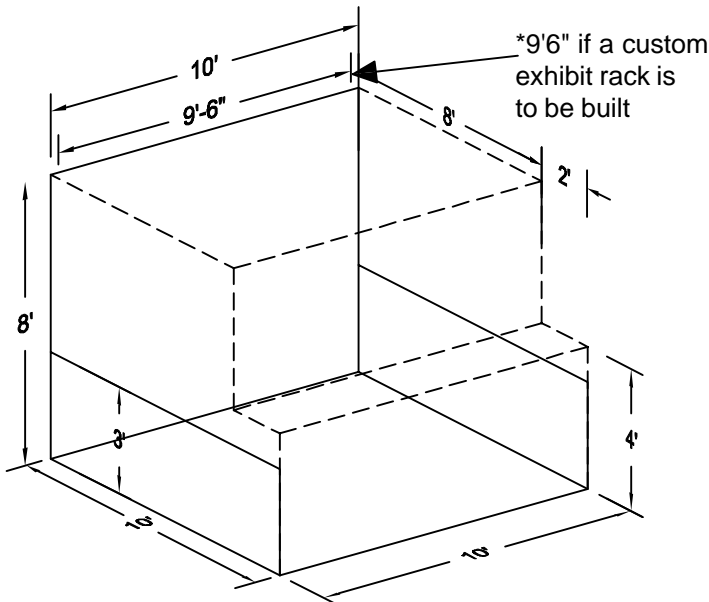
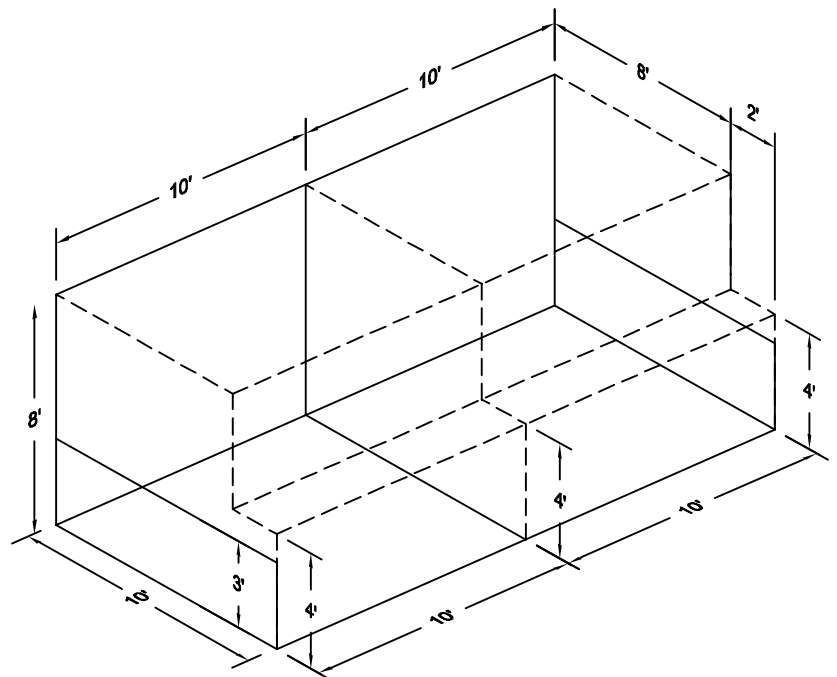

DIAGRAM 2 - MULTIPLE UNITS



Endcap Booths

An end cap booth space is 10' x 20' or larger and includes a 16-foot wide and 8-foot high centered pipe and drape backdrop. An end cap booth space is 10' x 20' or larger and includes a 16-foot wide and 8-foot high centered pipe and drape backdrop bookended by 3-foot high back curtains that separate you from the exhibitors behind you. From the side aisles, the first 2 feet of your booth space is limited to 4-feet in height for solid display material. (see shaded diagram).

From each side along the 3-foot high pipe and drape back curtains (shaded in the diagram), there are no height restrictions after the 2 feet of space from the aisle on both sides.*

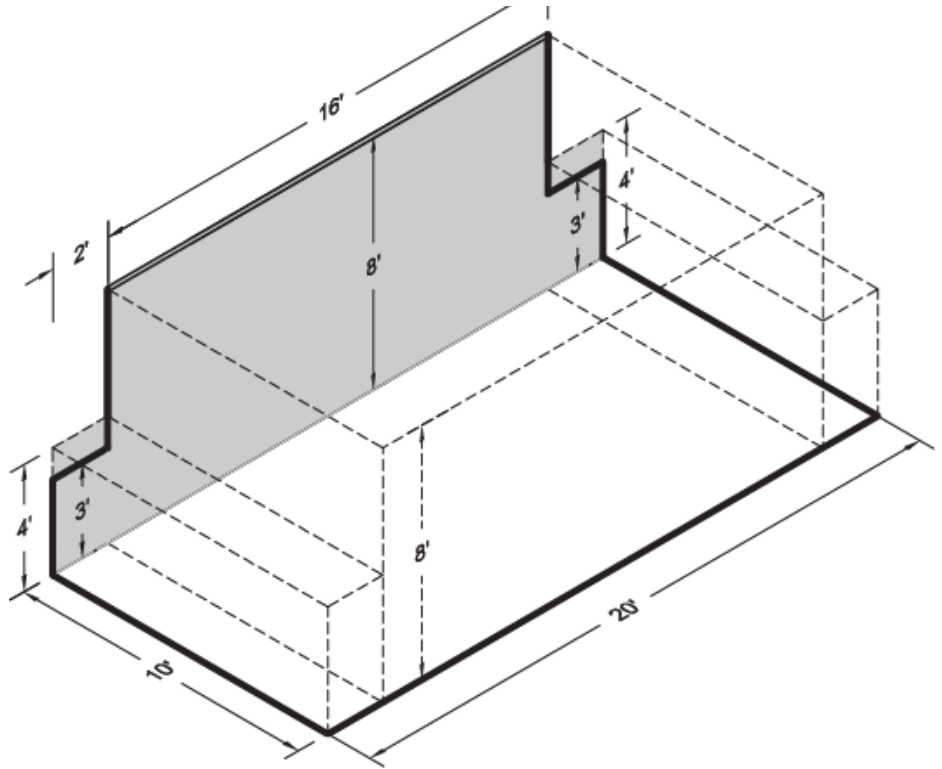

SPECIAL EQUIPMENT REQUIREMENTS:

The operation of oil, alcohol or gasoline engines is prohibited during show hours and all such engines must be free of all such fuels and fuel tank caps must be taped closed while on display in the exhibit area. In addition, all battery cables must be disconnected during exhibition of vehicles and cable ends must be taped to meet fire department regulations.

Audio-visual equipment is limited in its operation to sales demonstrations only and shall not be used for showings designed to attract or entertain visitors. All audio visual equipment shall be in accordance with the requirements of the fire prevention authorities and in harmony with any agreements entered into by the Farwest Show, the Oregon Convention Center and applicable labor unions. The use of loud speakers and public address equipment by exhibitors is absolutely prohibited. Exhibits which include the operation of musical instruments, radios or any noise-making equipment must be conducted or arranged so that the noise resulting from the demonstrations will not disturb adjacent exhibitors. All plans for installation and operation of special sound equipment must be approved by the Farwest Show prior to installation.

The Farwest Show does not have a performing rights license issued by ASCAP, thus, the performance or use of copyrighted music, whether live, tapes, CDs, videos, etc., is prohibited. Exhibitors are responsible for any action taken by ASCAP or other such organization. Failure to observe this rule may be grounds for removal from the show.

HAZARDOUS MATERIALS:

No exhibitor will be allowed to bring any hazardous material into the exhibit hall for any purpose during hours of move-in, show hours or move-out. The Farwest Show requires the use of empty display containers that have never been filled with hazardous materials. This rule will be strictly enforced. Hazardous materials are defined as follows:

Any material packaged in a container that has the words "danger", "warning" or "poison" on it, accompanied by a phrase such as, but not limited to, "do not get on skin," "do not get in eyes," "do not breathe dust," "live aerosol spray cans."

Rules and regulations set forth by the Portland Fire Bureau covering hazardous materials must be followed, or exhibits are subject to removal from the Show.

PETS:

Except for guide dogs, no animals or pets are permitted in exhibit hall or booths at any time without show management approval, which in turn, must get approval from the facility. It is also forbidden to house animals in automobiles or trucks parked on Convention Center property.

SECURITY:

The Farwest Show will attempt to provide adequate security service for the exhibit area during show hours as well as when the show is closed. As further protection, the Farwest Show encourages each exhibitor to have at least one employee in the booth during move-in and move-out hours. The ultimate responsibility of security lies with the exhibitor at all times and the Farwest Show shall not be held liable for the loss or theft of any or all items from an exhibit booth at any time.

Exhibitors are encouraged to secure and insure valuable items, including but not limited to televisions, computers, small equipment and tools. It is strongly suggested to remove such items immediately upon the close of the show. Please note, during move-in and move-out hours it is impossible to assure total protection of exhibits and items within them. Exhibitors can assist the Farwest Show by securing items of value during these hours.

EXHIBITORS CREDENTIALS:

In keeping with our efforts to provide exhibitors and show visitors with the best possible security, it is important that all exhibitors and guests wear, in clear view at all times, appropriate name badges. Exhibitor badges allow access onto the show floor prior to opening. Attendee badges are allowed access to the exhibit halls during posted show hours. Exhibitor badges are for exhibitors, show management and staff only. Please note that rules covering registration and security are for the protection and benefit of Farwest Show exhibitors.

NON-COMPLIANCE TO RULES AND REGULATIONS:

Each exhibitor, for himself/herself and his employees, substitutes or agents, agrees to abide by the rules and regulations given herein and by subsequent amendments and additions, considered by the Farwest Show to be in the best interest of all exhibitors. Upon non-compliance with the established rules, the Farwest Show reserves the right to prohibit, reject or eject any exhibitor, exhibitor's representative, exhibit (in whole or part) or visitor, with or without giving cause. In the event of restriction or eviction, the Farwest Show is not liable for any refunds on rentals or other exhibit expenses.

AMEDMENTS TO RULES:

These rules, regulations and conditions and the exhibitor's space agreements have been drawn for the purpose and intention of providing a well-balanced, regulated, attractive and successful exposition. Any and all matters, or questions not specifically covered by the preceding rules and regulations or the Exhibit Space Contract, shall be subject solely to the decision of the Farwest Show. The Farwest Show shall have full power to so interpret the rules and regulations, or make such judgments, as may appear to be for the best interests of the Farwest Show and the OAN, and any and all amendments of the foregoing rules, regulations and conditions shall bind the exhibitors.

LIMITATION OF LIABILITY:

It is expressly understood and agreed, and the exhibitor agrees by accepting these rules and regulations, and by signing the Exhibit Space Contract, that he/she will make no claim of any kind against the Farwest Show, the OAN, its members, employees or agents for any loss, damage or destruction of goods, nor for any injury or death that may occur to himself or his employees, associates, aides or guests while on the show grounds, nor for any damage of any nature or character whatsoever.

Rules and regulations contained above are considered to be in addition to rules and regulations printed on the Farwest Show Exhibit Space Contract. Signing of the exhibitor's contract accepts the conditions and limits listed above.